

### Manual Diaphragm Pumps

These are the traditional mainstay of small craft bilge pumping systems and can offer surprisingly good flow rates, as well as a variety of installation options. Yacht racing rules state that at least one pump must be capable of being pumped from the cockpit with all hatches shut. The best way to accomplish this is with a through deck kit which allows the pump to be installed safely below decks whilst the operator pumps from above. A well designed manual bilge pump is very hard to block due to its large bore hose and valves and one piece diaphragm. The larger pumps in Jabco's range of manual bilge pumps are also suitable for ballast and waste transfer.

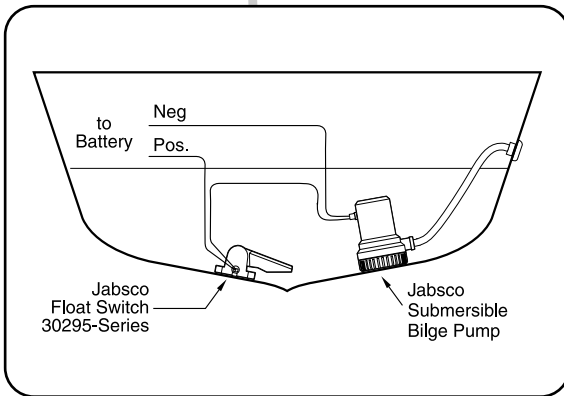

### Electric Submersible Pumps

Now by far the most popular type of electric bilge pumps, submersibles give very high outputs, are cost effective, have low amp draw and are easy to install. They are designed to fit in the lowest part of the bilge and only require discharge pipework and electricity supply. However, flow rates decrease more rapidly than other types of pumps as the discharge head increases, so check our recommended maximum discharge heads and if in doubt, always increase the size of the pump. Although our submersibles can be run dry for up to 2 hours, pump life can be extended by avoiding dry running whenever possible. All submersibles can be operated using a float or hydro-air switch, and remotely controlled outside the bilge compartment by using a Jabco switch panel

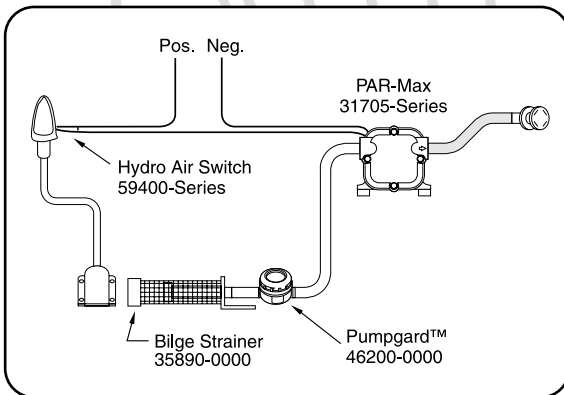

### Electric Diaphragm Pumps

These pumps are excellent for shallow bilge boats where the water left behind by other types of pump will slop from side to side. With the small size of inlet pipework they are very effective at removing all but the last drops of water. Diaphragm pumps can be run dry which removes the need to watch overboard outlets whilst the pump is running. The ability to self prime means they can be mounted in an easily accessible high and dry location to simplify installation and improve serviceability. Most models in our range are supplied complete with a Pumpgard™ strainer to protect the pumps from bilge debris.



## Electric Flexible Impeller Pumps

Flexible Impeller pumps make excellent bilge pumps, principally because of their ability to handle bilge debris without damage. Because of the robust design many owners still use our 12 volt DC or 24 volt DC flexible impeller motor pump units that are up to 25 years old! Flexible Impeller Pumps also give the benefits of good flow, low cost, low size and weight, and are easily serviced and maintained. Most Flexible Impeller pumps must not be run dry, as this will damage the impeller which will require replacing. However, the Utility Puppy 2000 and 3000 both allow a maximum of ten minutes dry running after initial prime. As with submersible pumps, flexible impeller pumps can be operated using a float or Hydro Air switch, and remotely controlled from outside the bilge compartment. There is a wide range of flexible impeller pumps to choose from giving a range of flows, discharge heads, and self priming options for a wide variety of applications such as ballast transfer, bait tank circulation, and deck wash duties.

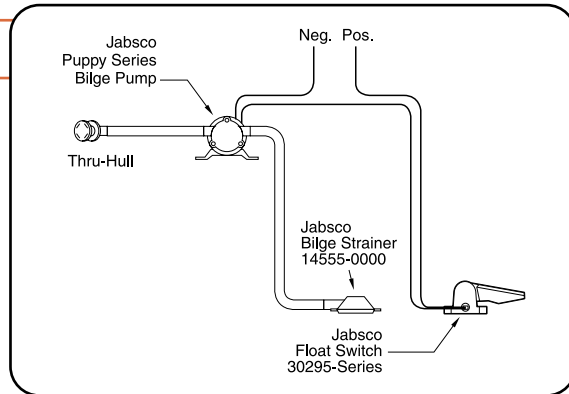

## Engine Driven Flexible Impeller Pumps

Jabsco engine driven pumps are probably the strongest and most reliable pumps produced today. Combined with other benefits such as self priming and very high flow rates, these pumps are now the firm favourites of commercial and professional mariners world wide. All the pumps are easily maintained and can fulfill a variety of duties on board both modern and classic vessels. Jabsco engine driven pumps come in a very wide range of performances and sizes and can be direct driven by either a clutch, pulley, hydraulic drive, or close coupled to a suitable power take off on the engine. These pumps are suitable for applications such as:

- High flow, heavy duty bilge pumps
- Emergency bilge pumps
- Fire fighting pumps
- Engine cooling
- Water Ballast transfer
- Circulation duties

Of course each application requires different features from each pump and drive type. Either manual or electromagnetic flexible impeller clutch pumps are ideal for bilge pumping. Each type of clutch has different benefits from the other. Manual clutches will operate as long as the engines are still running which provides added security when operating as an emergency bilge pump. Electromagnetic clutches can be operated remotely via float or Hydro Air switches, whilst fitting a vacuum switch eliminates all risk of dry running damage. However, electromagnetic clutches will only engage as long as electrical power remains available.

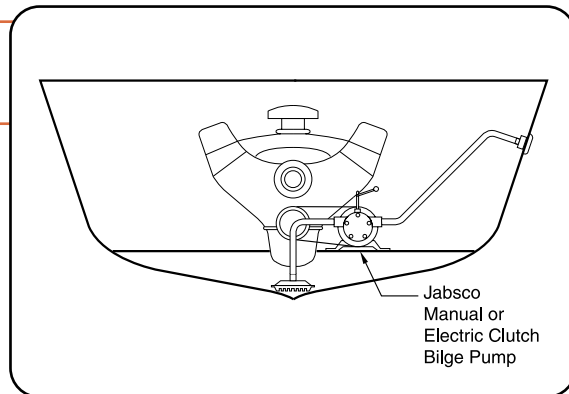

### WARNING

No pump manufactured by Jabsco should be used for petrol, petroleum products or any fluid with a flash point below 37°C (98F).



## Amazon Bulkhead

### For mounting on bulkhead or deck.

- Repositionable ports and body offer an amazing 96 assembly variations.
- Sustainable 45 lpm (10 gpm) output.
- Self priming up to 4m (13 ft).
- Corrosion resistant materials throughout.
- Stainless steel handle supplied with mounting clips and provision for safety lanyard.

**Fitting:** Connections for 25mm (1") id hose.

**Size:** 18cm wide x 20cm deep x 12cm high (7" x 8" x 4 3/4").

**Weight:** 0.6 kg (1.4 lb).

**29240-0000** Bulkhead Pump, c/w detachable handle.

**29246-1000** Service kit.

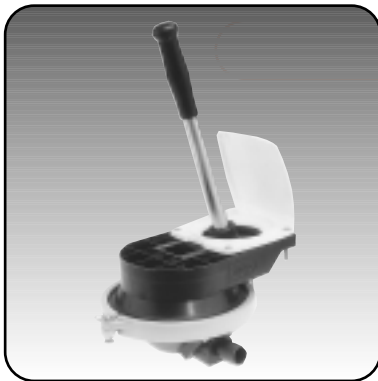

## Amazon Thru Deck

### For mounting through deck or through bulkhead.

- The ultimate compact through deck pump with no less than 16 port variations relative to the body.
- Readily achievable 50 lpm (11 gpm) output.
- Self priming up to 5m (16 ft).
- Loosening just one screw lets you clear blockages or position the body anywhere through 360° relative to the handle position.
- Compact design and low profile allow fitment in confined spaces.
- Sleekly styled Through Deck Kit and cover, with 4 mounting positions relative to the pump.
- Excellent solids handling ability for use with holding tanks.

■ Corrosion resistant materials throughout.

■ Stainless steel handle supplied with mounting clips and provision for safety lanyard.

**Fitting:** Connections for 25mm (1") id hose or 38mm (1 1/2") hose.

**Size:** 25cm long x 11cm wide x 12cm deep (10" x 4 7/16" x 4 1/2").

**Weight:** 1.2 kg (2 1/2 lbs).

**29250-0000** 25mm (1") Thru Deck Pump, c/w detachable handle and Through Deck Kit.

**29250-0010** 38mm (1 1/2") Thru Deck Pump, c/w detachable handle and Through Deck Kit.

**29256-1000** Service kit.



## Amazon Universal

### For mounting on bulkhead, through bulkhead, on deck or through deck.

- Unique safety feature allows operation from both inside and outside the cabin (with optional Through Deck Kit).
- Flow rate of up to 100 lpm (22 gpm).
- Self priming up to 3m (10ft).
- Push-fit inlet and outlet elbows swivel through 360° to increase flexibility of installation still further.
- Corrosion resistant materials throughout.
- Quick release clamp ring gives fast access for blockage clearance.
- 38mm (1 1/2") ports give excellent solids

handling ability for use with holding tanks.

■ Stainless steel handle supplied with mounting clips and provision for safety lanyard.

**Fitting:** Connections for 38mm (1 1/2") id hose.

**Size:** 24cm wide x 24cm high x 15cm deep (9 1/2" x 9 1/2" x 6").

**Weight:** 1.2 kg (2.9 lb).

**29270-0000** Universal Pump, c/w detachable handle and one push-fit elbow.

**29279-0000** Optional Through Deck Kit.

**29266-1000** Additional push-fit elbow.

**29276-1000** Service kit.



## Bilge Strainers

### Stops bilge debris blocking inlet suction hose and reduces the risk of debris entering and blocking the pump.

- Available to suit 19mm, 25mm and 38mm (3/4", 1" and 1 1/2") id hose.
- Non-return valve fitted to stop bilge water draining back when pumping stops.
- Repositional ports allow horizontal, vertical or sideways hose leads.
- Easily removable strainer plate for cleaning.

■ Corrosion resistant materials throughout.

**Fitting:** Connections for 19mm, 25mm or 38mm (3/4", 1" or 1 1/2") id hose.

**Size:** 17cm long x 7.2cm wide x 6cm high (6 3/4" x 2 7/8" x 2 1/2").

**Weight:** 0.1kg (1/4lb).

**29290-0020** Bilge Strainer for 19mm (3/4") id hose.

**29290-0000** Bilge Strainer for 25mm (1") id hose.

**29290-0010** Bilge Strainer for 38mm (1 1/2") id hose.

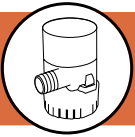

## Amazon Warrior

**For mounting on deck, or through deck (with optional Through Deck Kit and Bracket).**

- Robust design particularly suited to workboats and larger leisure craft, or any installation where particularly heavy duty is anticipated.
- 29280-0100 Model with swivel arms and captive wheel nuts meets DTI requirements for use on lifeboats.
- 45cm (18") handle assists sustained high outputs of up to 135 lpm (30 gpm).
- Self-priming up to 5.5m (17.5 ft).
- Double diaphragm design gives maximum efficiency, and added safety.
- 38mm (1 1/2") ports give large solids handling ability.

- Can function on one diaphragm in an emergency.
- Corrosion resistant materials throughout.

**Fitting:** Connections for 38mm (1 1/2") id hose.

**Size:** 35.5cm wide x 24cm high x 20cm deep (14" x 9 1/2" x 8")

**Weight:** 4.95 kg (11 lbs).

- 29280-0000** Warrior Pump, c/w detachable handle.
- 29280-0100** Warrior Pump, lifeboat version.
- 29279-0000** Optional Through Deck Kit.
- 29289-0000** Under Deck Bracket (required for use with Through Deck Kit).
- 29286-1000** Service kit.



## In-Line Non-Return Valves

**Non-return valves fit in suction pipework to aid priming and prevent backflow of water into the bilges.**

- Available for three hose sizes - 19mm, 25mm and 38mm (3/4", 1" and 1 1/2").
- Simply fitted into suction hose.
- Corrosion resistant materials throughout.

**Fitting:** Connections for 19mm, 25mm or 38mm (3/4", 1" or 1 1/2") id hose.

**Size:** 10.8cm long x 5.5cm wide x 5cm high (4 1/4" x 2 1/8" x 2")

**Weight:** 0.1kg (1/4 lb).

- 29295-0011** In-Line non-return valve for 19mm (3/4") id hose.
- 29295-0000** In-Line non-return valve for 25mm (1") id hose.
- 29295-0010** In-Line non-return valve for 38mm (1 1/2") id hose.

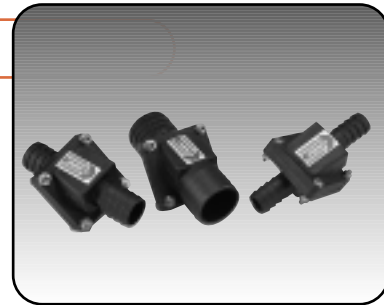

## Amazon Mounting Positions

### Amazon Bulkhead

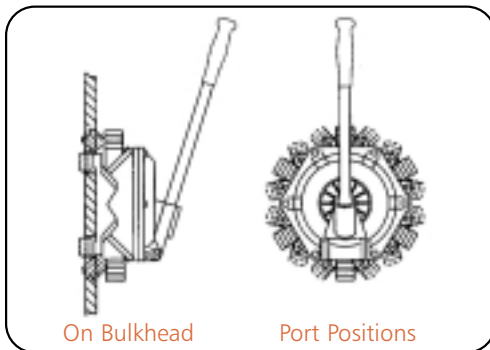

On Bulkhead

Port Positions

### Amazon Thru Deck

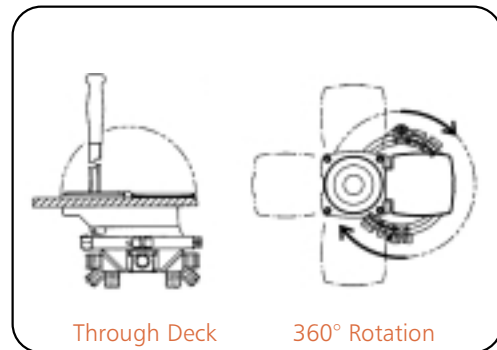

Through Deck

360° Rotation

### Amazon Universal

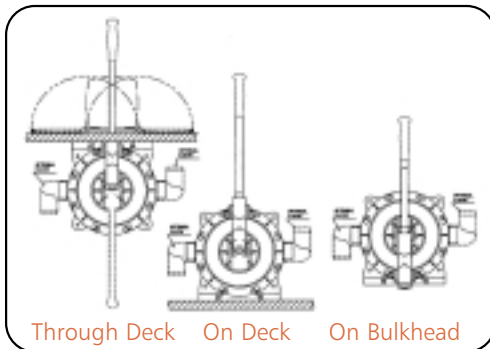

Through Deck

On Deck

On Bulkhead

### Amazon Warrior

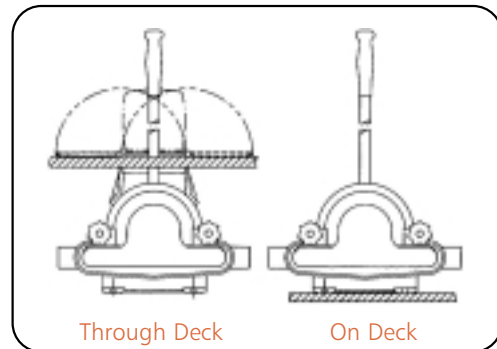

Through Deck

On Deck

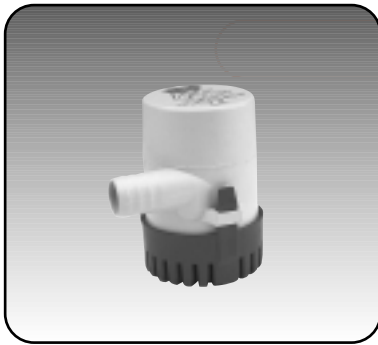

## Jabsco 450

**Super compact, big performer for smaller craft, speedboats, ski-boats, smaller launches and weekenders.**

- Recommended for discharge heads up to 2m (6ft).
- 1750 lph (375 gph) open flow output.
- Easy clean strainer.
- Low amp draw conserves batteries.
- Marine grade blocked wiring.
- Stainless steel shaft lengthens pump life.
- Motor life rated 1500 hours.

- ISO 8846 MARINE (Ignition protection).
- ISO 8849 MARINE (Bilge Pump Standard).

**Fitting:** Connections for 19mm (3/4") id hose.

**Size:** 9cm high x 6cm base diameter (3" x 2 3/8").

**Weight:** 0.3kg (0.6lb).

**30220-2012** 12 Volt dc model, fuse 2.5 amp.

**30220-2024** 24 Volt dc model, fuse 1.5 amp.



## Jabsco 750

**Compact, big performer for smaller craft.**

- Recommended for discharge heads up to 2m (6ft).
- 2900 lph (625 gph) open flow output.
- Motor rated for 1500 hours.
- Marine grade blocked wiring.
- Low amp draw conserves batteries.
- Stainless steel shaft lengthens pump life.
- ISO 8846 MARINE (Ignition Protection).

- ISO 8849 MARINE (Bilge Pump Standard).

**Fitting:** Connections for 19mm (3/4") id hose.

**Size:** 10cm high x 7.5cm base diameter (4" x 2 7/8").

**Weight:** 0.3kg (0.6lb).

**30222-2012** 12 Volt dc model, fuse 5 amp.

**30222-2024** 24 Volt dc model, fuse 3 amp.



## Jabsco 1050

**A compact model packed with features for smaller yachts and motor cruisers.**

- Suitable for discharge heads up to 3m (9ft).
- 4050 lph (875 gph) open flow output.
- Motor rated for more than 1500 hours.
- Anti-airlock design clears air traps in the pump.
- Marine grade blocked wiring.
- Stainless steel shaft lengthens pump life.

- ISO 8846 MARINE (Ignition protection).
- ISO 8849 MARINE (Bilge Pump Standard).

**Fitting:** Connections for 29mm (1 1/8") id hose.

**Size:** 11cm high x 6cm base diameter (4 1/4" x 2 3/8").

**Weight:** 0.3kg (0.6lbs).

**30230-2012** 12 Volt dc model, fuse 6 amps.

**30230-2024** 24 Volt dc model, fuse 1.5 amps.



## Jabsco 1950

**A high capacity pump for mid sized yachts and motor cruisers.**

- Suitable for discharge heads up to 3m (9ft).
- 7550 lph (1625 gph) open flow output.
- Motor rated for more than 2500 hours.
- Marine grade blocked wiring.
- Stainless steel shaft lengthens pump life.
- Anti-airlock design clears air traps in the pump.

- ISO 8846 MARINE (Ignition Protection).
- ISO 8849 MARINE (Bilge Pump Standard).

**Fitting:** Connections for 29mm (1 1/8") id hose.

**Size:** 15.5cm high x 10.5cm diameter (6" x 4 1/4").

**Weight:** 1.4kg (3lbs).

**30240-2012** 12 Volt dc model, fuse 15 amps.

**30240-2024** 24 Volt dc model, fuse 10 amps.

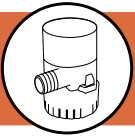

## Jabsco 3550

**Very high capacity for larger yachts and commercial vessels.**

- Suitable for discharge heads up to 4m (12ft).
- 13,750 lph (3000 gph) open flow output.
- Motor rated for more than 2500 hours.
- Marine grade blocked wiring.
- Stainless steel shaft lengthens pump life.
- Anti-airlock design clears air traps in the pump.

- ISO 8846 MARINE (Ignition Protection).
  - ISO 8849 MARINE (Bilge Pump Standard).
- Fitting:** Connections for 38mm (1 1/2") id hose.
- Size:** 18.5cm high x 12.5cm base diameter (7 1/4" x 4 7/8").
- Weight:** 2.3kg (5lbs).
- 30250-2012** 12 Volt dc model, fuse 25 amp.
- 30250-2024** 24 Volt dc model, fuse 15 amp.



## RS14 Float Switch & Cover

**Automatic on/off control of any 12 or 24 Volt dc electric bilge pump or bilge alarm up to 14 amps (12 Volt dc), 7 amps (24 Volt dc).**

- Optional switch cover to protect against accidental jamming in either on or off position by bilge debris.
- Switches on at 73mm (2 7/8") and off at 22mm (7/8").
- Switch design prevents rapid on/off cycling.

- Fitting:** 0.7m (2ft) cables to allow electrical connections to be made in dry locations.
- Size:** Switch - 4cm wide x 11.5cm long x 5cm high (1 1/2" x 4 1/2" x 2").  
Cover - 5.5cm wide x 15.5cm long x 8.5cm high (2 1/4" x 6 1/8" x 3 3/8").
- Weight:** Switch - 0.07kg (0.16lb)  
Cover - 0.1kg (0.22lb)
- 30295-2000** RS14 Float Switch.
- 30294-2000** RS14 Cover.



## CS20 Automatic Float Switch

**Automatic on/off control of any 12, 24 or 32 Volt dc electric bilge pump or alarm up to 20 amps.**

- Integral guard protects against jamming in either on or off position by bilge debris and dual level water slots.
- Manual test feature.
- Top exit 'stay-dry' wiring.
- Switches on at 69mm (2 3/4") and off at 22mm (7/8").
- Switch design prevents rapid on/off cycling.

- Fitting:** 0.7m (2ft) cables that exit the top to keep wire connections in dry locations.
- Size:** 12cm long x 63mm wide x 66mm high (4 3/4" x 2 1/2" x 2 5/8").
- Weight:** 0.15kg (1/3lb)
- 30297-2000** CS 20 Float Switch and Guard.



## Hydro Air Switch

**A new, ultra reliable bilge switch, which will automatically operate bilge pumps once water level reaches 55mm (2 1/16"). As water rises in the bilge, air pressure in the bell and tube increases, operating a diaphragm switch in the switch unit. All electrical components are clear of the water and no sensitive electronics are used.**

- Proven highly reliable design using new moulding techniques.
- Styling compliments modern interiors.
- Automatic operation of bilge pumps or audible and visual high water level alarms.
- Turns on at 55mm (2 1/16") off at 25mm (1").
- Diaphragm switch can be mounted up to 3m (10ft) above plastic airbell.

- Size:** Switch - 15.3cm long x 4.5cm high x 7.5cm wide (6" x 1 3/4" x 3")  
Airbell - 6cm long x 3cm wide x 10cm high (2 3/8" x 1 1/4" x 4")
- Weight:** Switch - 0.2kg (1/2lb).
- 59400-0012** Hydro Air Switch for 12 Volt dc, up to 20 amps.
- 59400-0024** Hydro Air Switch for 24 Volt dc, up to 10 amps.





## PAR-Max 4 31705

**New generation, continuous rated bilge pump with waterproof coating for harsh environments.**

- 1000 lph (258 gph) open flow output
- Self priming up to 3m (10ft) allows mounting above wet bilges.
- Diaphragm design allows extended dry running.
- Build-in thermal overload protection.
- Complete with Pumpgard™ strainer.
- ISO 8846 MARINE (Ignition Protection).
- ISO 8849 MARINE (Bilge Pump Standard).

**Fitting:** Connections for 19mm (3/4") id hose.

**Size:** 18cm long x 10.5cm wide x 10cm high (7 1/4" x 4 1/8" x 4 1/10").

**Weight:** 2.5kg (5.5lb).

**31705-0092** 12 Volt dc, fuse 10 amp.

**31705-0094** 24 Volt dc, fuse 7 amp.

**18912-3050** Diaphragm kit

*For service and spare parts listing see page 160.*



## 37202 Series 2

**Updated version of the famous 37202 bilge, shower and sink drain pump, quiet running and corrosion resistant.**

- 780 lph (170 gph) open flow output.
- Self-priming up to 2m (6ft) vertical lift.
- Diaphragm design allows extended dry running.
- Complete with Pumpgard™ pre-filter.
- ISO 8846 MARINE (Ignition Protection).
- ISO 8849 MARINE (Bilge Pump Standard).

**Fitting:** Connections for 19mm (3/4") id hose.

**Size:** 13cm wide x 15cm high x 19cm deep (5 1/4" x 5 3/4" x 7 1/2").

**Weight:** 2.5kg (5 1/2lb).

**37202-2012** 12 Volt dc model, fuse 10 amp.

**37202-2024** 24 Volt dc model, fuse 5 amp.

**50095-1000** Service kit

*For service and spare parts listing see page 153.*



## PAR 36680

**Fully serviceable, bilge and deckwash pump.**

- 1250 lph (275 gph) open flow output.
- Self-priming up to 2m (7ft) vertical lift, allows mounting above wet bilges.
- Diaphragm design allows extended dry running.
- Complete with Pumpgard™ pre-filter.
- ISO 8846 MARINE (Ignition Protection).
- ISO 8849 MARINE (Bilge Pump Standard).

**Fitting:** Connections for 19mm (3/4") id hose.

**Size:** 14cm long x 17cm wide x 21cm high (6" x 6 3/8" x 8 1/4").

**Weight:** 6kg (8lb).

**36680-2000** 12 Volt dc model, fuse 10 amp.

**36680-2010** 24 Volt dc model, fuse 6 amp.

**43990-0062** Service kit (new, -2xxx models only).

*For service and spare parts listing see page 155.*



## PAR 36600

### Fully serviceable, bilge pump.

- 1800 lph (400 gph) open flow output.
- Self-priming up to 3m (10ft) vertical lift, allows mounting above wet bilges.
- Diaphragm design allows extended dry running.
- Complete with Pumpgard™ strainer.
- ISO 8846 MARINE (Ignition Protection).
- ISO 8849 MARINE (Bilge Pump Standard).

**Fitting:** Connections for 19mm (3/4") id hose.

**Size:** 14cm long x 18cm wide x 21cm high (6" x 7" x 8 1/4").

**Weight:** 5kg (11lb).

**36600-0000** 12 Volt dc model, fuse 15 amp.

**36600-0010** 24 Volt dc model, fuse 8 amp.

**30124-0000** Service kit.

*For service and spare parts listing see page 155.*



Included

## PAR 34600

### Fully serviceable, bilge pump.

- 2450 lph (550 gph) open flow output.
- Self-priming up to 3m (10ft) vertical lift, allows mounting above wet bilges.
- Diaphragm design allows extended dry running.
- Permanently lubricated ball bearings add to pump life.
- ISO 8846 MARINE (Ignition Protection).
- ISO 8849 MARINE (Bilge Pump Standard).

**Fitting:** Connections for 25mm (1") id hose.

**Size:** 18cm long x 22cm wide x 27cm high (7" x 8 1/2" x 10 1/2").

**Weight:** 6kg (13lb).

**34600-0000** 12 Volt dc model, fuse 15 amp.

**34600-0010** 24 Volt dc model, fuse 8 amp.

*Requires a Bilge Strainer, see accessories page 55.*

**30101-0000** Service kit.

*For service and spare parts listing see page 154.*



## Bilge Pumpgard™ Strainers

### Inlet Strainer protects all electric diaphragm pumps.

- Pre-filter protects all electric diaphragm bilge pumps.
- Prevents unnecessary pump breakdowns caused by particles in the water.
- Transparent housing allows instant inspection.
- 46200-0000 model installs in-line between bilge strainer and pump.
- Quick in-place cleaning of the 20 mesh stainless steel filter screen.

**Fitting:** Connections for 19mm (3/4") id hose.

**Weight:** 0.2kg (1/2lb).

**Size:** 12cm long x 7cm wide x 6cm high (4 3/4" x 2 3/4" x 2 1/2").

**46200-0000** Model for 19mm (3/4") id hose.

**46200-0010** Model for 19mm (3/4") id hose, 90 degree inlet and direct plug into PAR-Max inlet port.



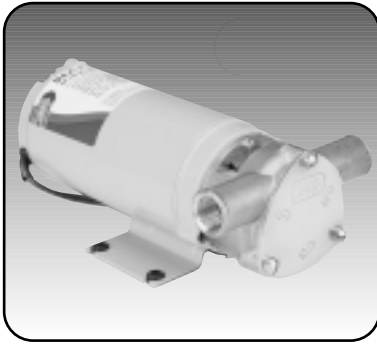
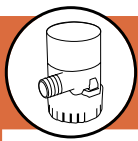

### Maxi Puppy 3000

**High flow, continuously rated bilge pump offering good discharge head.**

- 2640 lph (580 gph) output at 3m (10ft) total head.
- Self-priming up to 2.4m (8ft) vertical lift.
- Bilge debris presents no problem to this bronze bodied, flexible impeller design.
- Simple design means fewer wearing parts - all user serviceable.
- ISO 8846 MARINE (Ignition Protected).
- ISO 8849 MARINE (Bilge Pump Standard).

**Fitting:** Connections for 25mm (1") id hose, or 1/2" male threads. Do not use pipework of less than 19 mm (3/4") internal diameter.

**Size:** 22cm long x 12cm wide x 9cm high (8 1/2" x 4 3/4" x 3 1/2").

**Weight:** 3.6kg (8lb).

**23610-3012** 12 Volt dc model, fuse 20 amp.

**23610-3024** 24 Volt dc model, fuse 10 amp.

**7273-0003** Replacement impeller.

*For service and spare parts listing see page 152.*

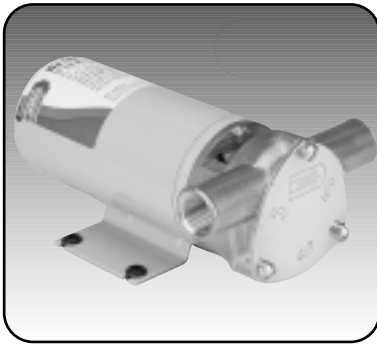

### Water Puppy 2000

**Good flow rate, continuously rated bilge pump.**

- 1920 lph (390 gph) output at 3m (10ft) total head.
- Self-priming up to 1.2m (4ft) vertical lift.
- Bilge debris presents no problem to this bronze bodied, flexible impeller pump.
- Simple design means fewer wearing parts - all user serviceable.
- ISO 8846 MARINE (Ignition Protection).
- ISO 8849 MARINE (Bilge Pump Standard).

**Fitting:** Connections for 1/2" male threaded fittings, and for 25mm (1") id hose.

**Size:** 19cm long x 12cm wide x 8cm high (7 1/2" x 4 3/4" x 3 3/8").

**Weight:** 3kg (6 1/2lb).

**23680-3012** 12 Volt dc model, fuse 15 amp.

**23680-3024** 24 Volt dc model, fuse 10 amp.

**6303-0003** Replacement Impeller.

*For service and spare parts listing, see page 152.*

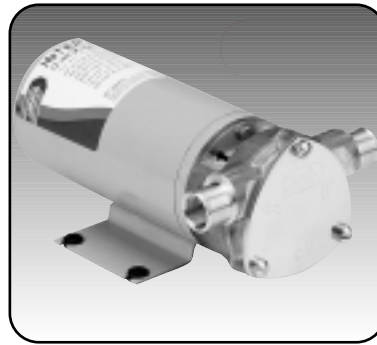

### InterPuppy

**High discharge head continuously rated bilge pump.**

- 900 lph (200 gph) output at 3m (10ft) total head.
- Self-priming up to 1.5m (5ft) vertical lift.
- Bilge debris presents no problem to this bronze bodied, flexible impeller design.
- Simple design means fewer wearing parts - all user serviceable.
- ISO 8846 MARINE (Ignition protected).
- ISO 8849 MARINE (Bilge pump standard).

**Fitting:** Connections for 3/8" BSP male threads, or 19mm (3/4") id hose.

**Size:** 18cm long x 11cm wide x 9 cm high (7 1/8" x 4 1/4" x 3 1/4").

**Weight:** 2.2kg (5lb).

**22010-2653** 12 Bolt dc model, fuse 15 amp.

**22010-2753** 24 volt dc model, fuse 10 amp.

**SK400-0023** Service kit, includes 9200-0003 nitrile impeller.

*For service and spare parts listing, see page 152.*



### Jabsco Bilge Control Switch

**Automatic bilge switch panel with 3-way switch and front access fuse holder for any automatically controlled 12 or 24 Volt dc bilge pump up to 20 amps.**

- Three way switch allows off, automatic or manual positions.
- Red light shows that automatic mode is set.
- Matt black modular styling blends with modern control panels.
- Mounting screws supplied.

**Size:** 7.5cm wide x 6cm high (3" x 2 1/2").

**Weight:** 100gm (4oz).

**29145-0012** Illuminated switch panel for 12 Volt dc up to 20 amps.

**29145-0024** Illuminated switch panel for 24 Volt dc up to 10 amps.

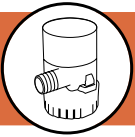

## Utility Puppy 2000

Continuous rated Utility Puppy 2000 offers high flow for bilge, deck wash and general purpose use, and twenty minutes dry running.

- 1920 lph (390 gph) output at 3m (10ft) total head.
- Dry running for twenty minutes after initial use.
- Self priming up to 1.2m (4ft) vertical lift.
- Bilge debris presents no problem to this bronze bodied, flexible impeller design.
- Simple design means fewer wearing parts - all user serviceable.

- ISO 8846 MARINE (Ignition Protection).
  - ISO 8849 MARINE (Bilge Pump Standard).
- Fitting:** Connections for 3/4" BSP male threads.
- Size:** 19cm long x 12cm wide x 9cm high (7 1/2" x 4 3/4" x 3 1/2").
- Weight:** 3.4kg (9.7lb).
- 23920-2403** 12 Volt dc model, fuse 15 amp.
- 23920-2503** 24 Volt dc model, fuse 10 amp.

*For service and spare parts listing see page 152.*



## Utility Puppy 3000

Continuous rated heavy duty Utility Puppy 3000 offers very high flow for bilge, deck wash and general purpose use, and ten minutes dry running.

- 2580 lph (570 gph) output at 3m (10ft) total head.
- Dry running for ten minutes after initial use.
- Self priming up to 2.4m (8ft) vertical lift.
- Mechanical seal for extra long life.
- Bilge debris presents no problem to this bronze bodied, flexible impeller design.
- Simple design means fewer wearing parts - all user serviceable.

- ISO 8846 MARINE (Ignition Protection).
  - ISO 8849 MARINE (Bilge Pump Standard).
- Fitting:** Connections for 3/4" BSP male threads.
- Size:** 22cm long x 12cm wide x 9cm high (8 1/2" x 4 3/4" x 3 1/2").
- Weight:** 4.0kg (8.2lb).
- 23920-2213** 12 Volt dc model, fuse 25 amp.
- 23920-2313** 24 Volt dc model, fuse 15 amp.

*For service and spare parts listing see page 152.*



## High Capacity Bilge Strainers

Large strainer surface area ensures unrestricted suction for high capacity bilge pumps.

- Adjustable mounting bracket for different hull shapes.
- Brass body with polypropylene strainer.
- Models for 19mm (3/4") and 25mm (1") id hose.

- Fitting:** Connections for 19mm (3/4") or 25mm (1") id hose
- Size:** 35cm long x 5cm diameter (13 1/2" x 1 3/4").
- Weight:** 0.25kg (1/2lb).
- 35890-0000** High Capacity Strainer for 19cm (3/4") id hose.
- 35890-0010** High Capacity Strainer for 25cm (1") id hose.



## Low Profile Bilge Strainer

The Low-Profile Bilge Strainer will reduce bilge-water levels to less than 6mm (1/4").

- Robust, one-piece naval bronze casting.
- Integral cast bronze mounting tabs.
- 3mm (1/8") high x 13mm (1/2") wide strainer slots.

- Fitting:** Connection for 13mm (1/2") hose barb.
- Size:** 25mm high x 60mm diameter (1" x 2 3/8")
- Weight:** 0.25kg (1/2lb)
- 14555-0000** Low Profile Bilge Strainer.

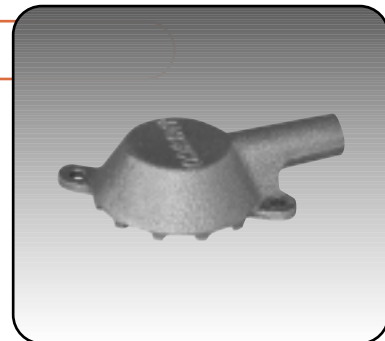



## 50270 Series Electric Clutch Pumps

**Very heavy duty bilge and deckwash pump belt driven from the engine, for leisure and commercial craft.**

- 22,000 lph (4,840 gph) at 3m (10ft) total head @ 1,500 rpm.
- Self Priming up to 4.5m (15ft) vertical lift.
- Bilge debris present no problems to this robust bronze bodied flexible impeller pump.
- Can be remotely controlled from outside the engine room and can be automatically shut off by fitting a vacuum cut off switch.
- Neoprene impeller is fitted as standard.

**Fitting:** 2" BSP Internal Thread/  
Optional 2" Flange.

**Size:** 264mm long x 170mm wide  
x 178mm high (10" x 7" x 7").

**Weight:** 12.2kg (27lb).

- 50270-X011** 12 Volt dc 2A Pulley E/M Clutch, fuse 5 amp
- 50270-X111** 24 Volt dc 2A Pulley E/M Clutch, fuse 2.5 amp
- 50270-X211** 12 Volt dc 1B Pulley E/M Clutch, fuse 5 amp
- 50270-X311** 24 Volt dc 1B Pulley E/M Clutch, fuse 2.5 amp

'X' = 0, flanged ports, 'X' = 2, BSP ports

*For service and spare parts listing see pages 121-144.*



## 50220 Series Electric Clutch Pumps

**Very heavy duty bilge, deckwash, and fire fighting pump belt driven from the engine, for leisure and commercial craft.**

- 15,000 lph (3,300 gph) at 3m (10ft) total head @ 1,500 rpm.
- Self Priming up to 4.5m (15ft) vertical lift.
- Bilge debris present no problems to this robust bronze bodied flexible impeller pump.
- Can be remotely controlled from outside the engine room and can be automatically shut off by fitting a vacuum cut off switch.
- Neoprene impeller is fitted as standard.

**Fitting:** 1/2" Flange

**Size:** 239mm long x 153mm wide  
x 178mm high (9 1/2" x 6" x 7").

**Weight:** 11.2kg (25lbs).

- 50220-0011** 12 Volt dc 2A Pulley E/M Clutch, fuse 5 amp
- 50220-0111** 24 Volt dc 2A Pulley E/M Clutch, fuse 2.5 amp
- 50220-0211** 12 Volt dc 1B Pulley E/M Clutch, fuse 5 amp
- 50220-0311** 24 Volt dc 1B Pulley E/M Clutch, fuse 2.5 amp

*For service and spare parts listing see pages 121-144.*

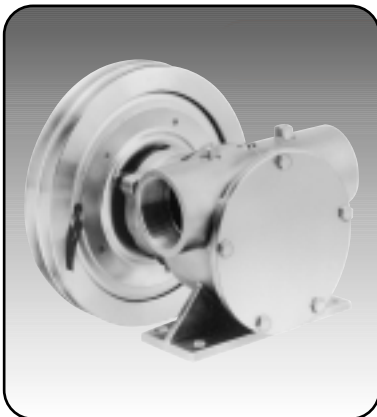

## 50200 Series Electric Clutch Pumps

**Very heavy duty bilge, deckwash, and firefighting pump belt driven from the engine, for leisure and commercial craft.**

- 15,000 lph (3,300 gph) at 3m (10ft) total head @ 1,500 rpm.
- Self Priming up to 4.5m (15ft) vertical lift.
- Bilge debris present no problems to this robust bronze bodied flexible impeller pump.
- Can be remotely controlled from outside the engine room and can be automatically shut off by fitting a vacuum cut off switch.
- Neoprene impeller is fitted as standard.

**Fitting:** 1 1/2" BSP Internal Thread.

**Size:** 239mm long x 153mm wide  
x 178mm high (9 1/2" x 6" x 7").

**Weight:** 11.2kg (25lbs).

- 50200-2011** 12 Volt dc 2A Pulley E/M Clutch, fuse 5 amp
- 50200-2111** 24 Volt dc 2A Pulley E/M Clutch, fuse 2.5 amp
- 50200-2211** 12 Volt dc 1B Pulley E/M Clutch, fuse 5 amp
- 50200-2311** 24 Volt dc 1B Pulley E/M Clutch, fuse 2.5 amp

*For service and spare parts listing see pages 121-144.*



## 50080 Series Electric Clutch Pumps

**Heavy duty bilge and deckwash pump belt driven from the engine, for leisure and commercial craft.**

- 6,400 lph (1,408 gph) at 3m (10ft) total head @ 1,500 rpm.
- Self Priming up to 4.5m (15ft) vertical lift.
- Bilge debris present no problems to this robust bronze bodied flexible impeller pump.
- Can be remotely controlled from outside the engine room and can be automatically shut off by fitting a vacuum cut off switch.
- Neoprene impeller is fitted as standard.

**Size:** 160mm long x 120mm wide  
x 178mm high (6" x 5" x 7").

**Weight:** 5kg (11lbs).

- 50080-2001** 12 Volt dc 2A Pulley E/M Clutch, fuse 5 amp
- 50080-2101** 24 Volt dc 2A Pulley E/M Clutch, fuse 2.5 amp
- 50080-2201** 12 Volt dc 1B Pulley E/M Clutch, fuse 5 amp
- 50080-2301** 24 Volt dc 1B Pulley E/M Clutch, fuse 2.5 amp

*For service and spare parts listing see pages 121-144.*

**Fitting:** 1" BSP Internal Thread

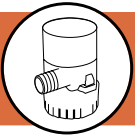

## 51270 Series Manual Clutch Pumps

**Very heavy duty bilge, deckwash, and fire-fighting pump belt driven from the engine, for leisure and commercial craft.**

- 22,000 lph (4,840 gph) at 3m (10ft) total head @ 1,500 rpm.
- Self priming up to 4.5m (15ft) vertical lift.
- Bilge debris present no problems to this robust bronze bodied flexible impeller pump.
- Dependable manual control will operate even under the toughest conditions.
- Clutch pulley will accommodate both A and B type pulley belts.

- Easily serviced and maintained.
- Neoprene impeller is fitted as standard.

**Fitting:** 2" BSP Internal Thread/  
Optional 2" Flange

**Size:** 316mm long x 170mm wide  
x 224mm high (12" x 7" x 9").

**Weight:** 11kg (25lbs).

**51270-0011** Manual Clutch, flanged ports

**51270-2011** Manual Clutch, BSP ports

*For service and spare parts listing see pages 121-144.*



## 51220 Series Manual Clutch Pumps

**Very heavy duty bilge, deckwash, and fire-fighting pump belt driven from the engine, for leisure and commercial craft.**

- 15,000 lph (3,300 gph) at 3m (10ft) total head @ 1,500 rpm.
- Self Priming up to 4.5m (15ft) vertical lift.
- Bilge debris present no problems to this robust bronze bodied flexible impeller pump.
- Dependable manual control will operate even under the toughest conditions.

- Clutch pulley will accommodate both A and B type pulley belts.
- Easily serviced and maintained.
- Neoprene impeller is fitted as standard.

**Fitting:** 1 1/2" Flange

**Size:** 292mm long x 152mm wide  
x 226mm high (11 1/2" x 6" x 9").

**Weight:** 10kg (22lbs).

**51220-0011** Manual Clutch

*For service and spare parts listing see pages 121-144.*

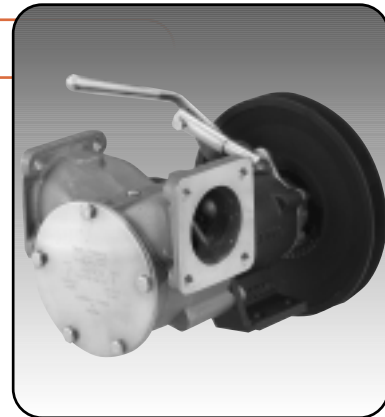

## 51200 Series Manual Clutch Pumps

**Heavy duty bilge and deckwash pump belt driven from the engine, for leisure and commercial craft.**

- 15,000 lph (3,300 gph) at 3m (10ft) total head @ 1,500 rpm.
- Self Priming up to 4.5m (15ft) vertical lift.
- Bilge debris present no problems to this robust bronze bodied flexible impeller pump.
- Dependable manual control will operate even under the toughest conditions.
- Clutch pulley will accommodate both A and B type pulley belts.

- Easily serviced and maintained.
- Neoprene impeller is fitted as standard, optional nitrile impeller available.

**Fitting:** 1 1/2" BSP Internal Thread

**Size:** 244mm long x 150mm x wide  
x 226mm high (9 1/2" x 6" x 9").

**Weight:** 8kg (18lbs).

**51200-2011** Manual Clutch

*For service and spare parts listing see pages 121-144.*

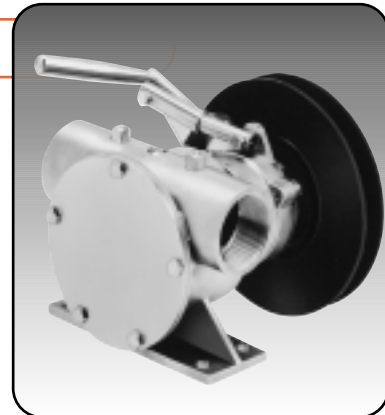

## 51080 Series Manual Clutch Pumps

**Heavy duty bilge and deckwash pump belt driven from the engine, for leisure and commercial craft.**

- 6,400 lph (1,408 gph) at 3m (10ft) total head @ 1,500 rpm.
- Self Priming up to 4.5m (15ft) vertical lift.
- Bilge debris present no problems to this robust bronze bodied flexible impeller pump.
- Dependable manual control will operate even under the toughest conditions.
- Clutch pulley will accommodate both A and B type pulley belts.

- Easily serviced and maintained.
- Neoprene impeller is fitted as standard.

**Fitting:** 1" BSP Internal Thread

**Size:** 198mm long x 120mm x wide  
x 189mm high (8" x 5" x 7 1/2").

**Weight:** 5kg (11lbs).

**51080-2001** Manual Clutch

*For service and spare parts listing see pages 121-144.*



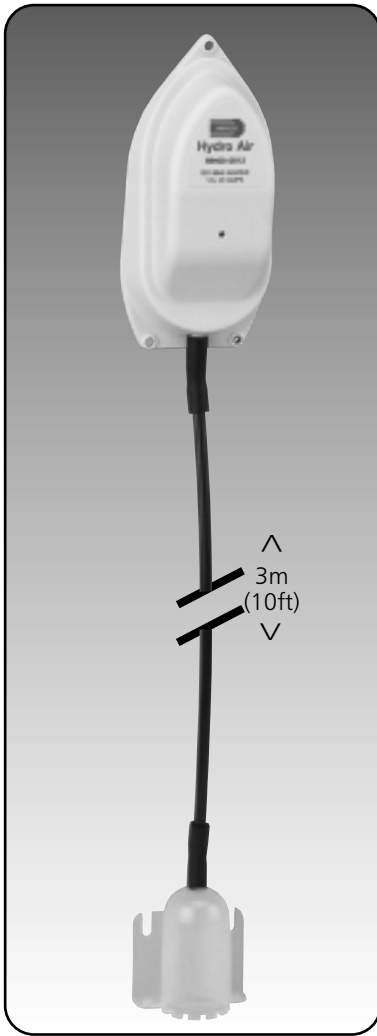

### Hydro Air Switch

A new, ultra reliable bilge switch, which will automatically operate bilge pumps once water level reaches 55mm (2<sup>3</sup>/<sub>16</sub>" ). As water rises in the bilge, air pressure in the bell and tube increases, operating a diaphragm switch in the switch unit. All electrical components are clear of the water and no sensitive electronics are used.

- Proven highly reliable design using new moulding techniques.
- Styling compliments modern interiors.
- Automatic operation of bilge pumps or audible and visual high water level alarms.

- Turns on at 55mm (2<sup>3</sup>/<sub>16</sub>" ) off at 25mm (1").
- Diaphragm switch can be mounted up to 3m (10ft) above plastic airbell.

**Size:** Switch - 15.3cm long x 4.5cm high x 7.5cm wide (6" x 1<sup>3</sup>/<sub>4</sub>" x 3")  
Airbell - 6cm long x 3cm wide x 10cm high (2<sup>3</sup>/<sub>8</sub>" x 1<sup>1</sup>/<sub>4</sub>" x 4")

**Weight:** Switch - 0.2kg (1/2lb).

**59400-0012** Hydro Air Switch for 12 Volt dc, up to 20 amps.

**59400-0024** Hydro Air Switch for 24 Volt dc, up to 10 amps.

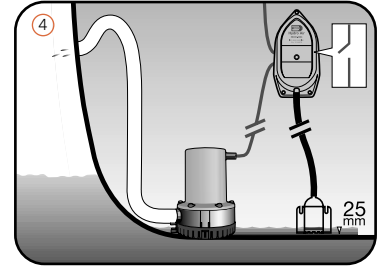
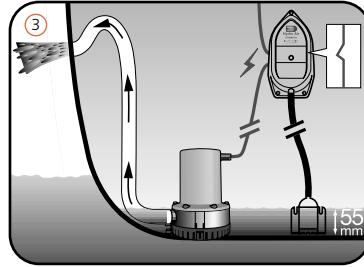
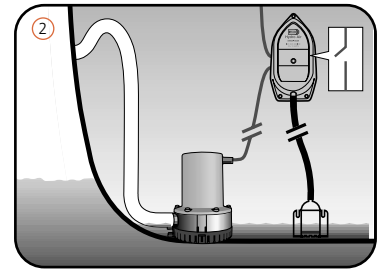
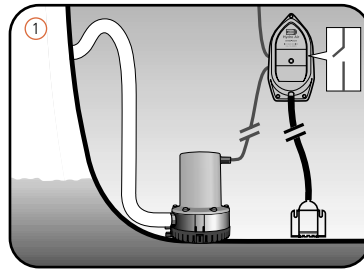

### RS14 Float Switch & Cover

Automatic on/off control of any 12 or 24 Volt dc electric bilge pump or bilge alarm up to 14 amps (12 Volt dc), 7 amps (24 Volt dc).

- Optional switch cover to protect against accidental jamming in either on or off position by bilge debris.
- Switches on at 73mm (2<sup>7</sup>/<sub>8</sub>" ) and off at 22mm (7/8").
- Switch design prevents rapid on/off cycling.

**Fitting:** 0.7m (2ft) cables to allow electrical connections to be made in dry locations.

**Size:** Switch - 4cm wide x 11.5cm long x 5cm high (1<sup>1</sup>/<sub>2</sub>" x 4<sup>1</sup>/<sub>2</sub>" x 2").

Cover - 5.5cm wide x 15.5cm long x 8.5cm high (2<sup>1</sup>/<sub>4</sub>" x 6<sup>1</sup>/<sub>8</sub>" x 3<sup>3</sup>/<sub>8</sub>" ).

**Weight:** Switch - 0.07kg (0.16lb)  
Cover - 0.1kg (0.22lb)

**30295-2000** RS14 Float Switch.

**30294-2000** RS14 Cover.



### CS20 Automatic Float Switch

Automatic on/off control of any 12, 24 or 32 Volt dc electric bilge pump or alarm up to 20 amps.

- Integral guard protects against jamming in either on or off position by bilge debris and dual level water slots.
- Manual test feature.
- Top exit 'stay-dry' wiring.
- Switches on at 69mm (2<sup>3</sup>/<sub>4</sub>" ) and off at 22mm (7/8").

- Switch design prevents rapid on/off cycling.

**Fitting:** Supplied with 0.7m (2ft) cables that exit the top to keep wire connections in dry locations.

**Size:** 12cm long x 63mm wide x 66mm high (4<sup>3</sup>/<sub>4</sub>" x 2<sup>1</sup>/<sub>2</sub>" x 2<sup>5</sup>/<sub>8</sub>" )

**Weight:** 0.15kg (1/3lb)

**30297-2000** CS 20 Float Switch and Guard.